

FLAT BOTTOM INCLINE CONVEYORS

Head Features:

- Computer aided modular bolt together design
- CNC manufactured
- 10-8-5 gauge standard galvanized construction
- Heavy duty pillow block bearings
- Heavy duty drive sprocket
- Removable inspection cover
- Dust seals

Trough features:

- Computer aided modular bolt together design
- CNC manufactured
- 10 gauge galvanized sides
- 10-8-5 gauge galvanized bottoms available
- UHMW return rollers
- Pre-assembled trunk sections
- Optional abrasion resistant steel liners for bottom and sides

Tail Features:

- Computer aided modular bolt together design
- CNC Manufactured
- 10-8-5 gauge standard galvanized construction
- Heavy duty pillow block bearings
- Heavy duty sprocket
- Acme screw slack adjusters
- Removable inspection covers
- Dust seals

FLAT BOTTOM

INCLINE CONVEYORS



BPH	Drag Size	RPM	FPM
1,000	GLID-09X14	34	74
1,500	GLID-09X14	51	110
2,100	GLID-09X14	71	154
2,500	GLID-09X14	85	185
3,100	GLID-12X14	69	155
3,400	GLID-12X14	78	170
3,900	GLID-12X14	90	195
4,000	GLID-17X20	29	99
5,000	GLID-17X20	36	124
6,000	GLID-17X20	43	149
7,000	GLID-17X20	50	174
7,000	GLID--24X24	26	106
8,000	GLID--24X24	29	121
9,000	GLID--24X24	33	134
10,000	GLID--24X24	37	152
10,000	GLID--32X24	27	110
12,500	GLID--32X24	33	138
15,000	GLID--32X24	40	165

	9X14	12X14	17X20	24X24	32X24
A	9	12	17	24	32
B	14	14	20	24	24
C	29 ⁷ / ₈	32 ⁷ / ₈	41 ⁷ / ₈	51 ⁷ / ₈	59 ⁷ / ₈
F	68	68	73	78	78
G	120	120	120	120	120
H	60	60	60	60	60
J	20	20	20	30	30
K	3 1/2	3 1/4	3 3/8	3 1/2	3 1/2
L	36	36	36	46	46
M	252	252	260	265	295
P	30	33	42	52	60
Q	26	26	34	41	45

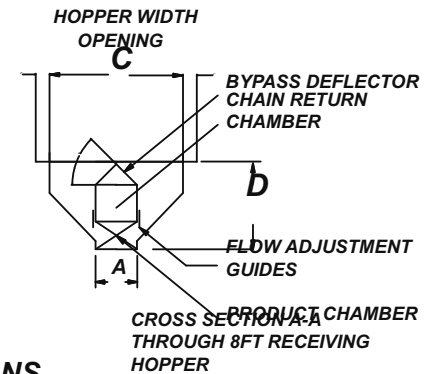
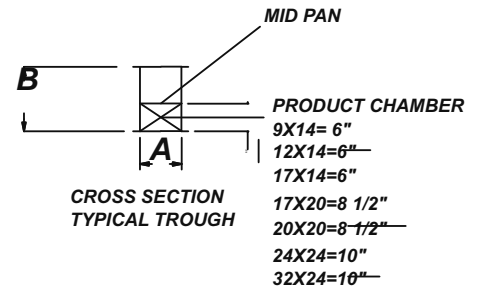
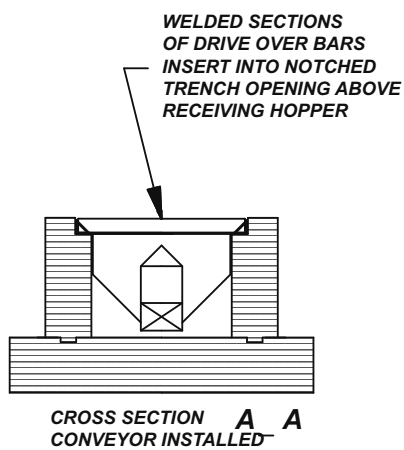
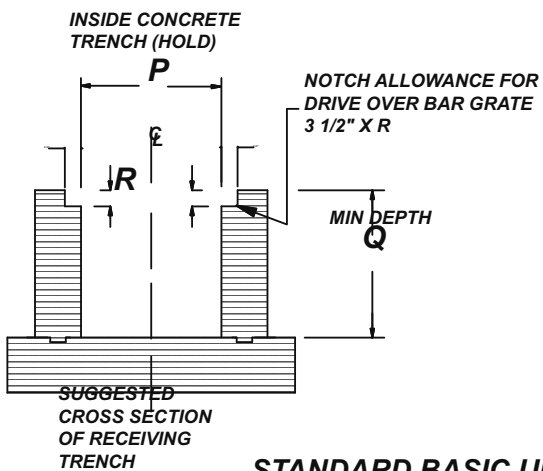

STANDARD BASIC UNIT LENGTH PLUS OPTIONAL 60\"/>

CENTRE PAN THROUGH FULL LENGTH OF CONVEYOR PLUS OPTIONAL 60\"/>

HEAD SECTION
R/H OR L/H
DRIVE OPTIONS

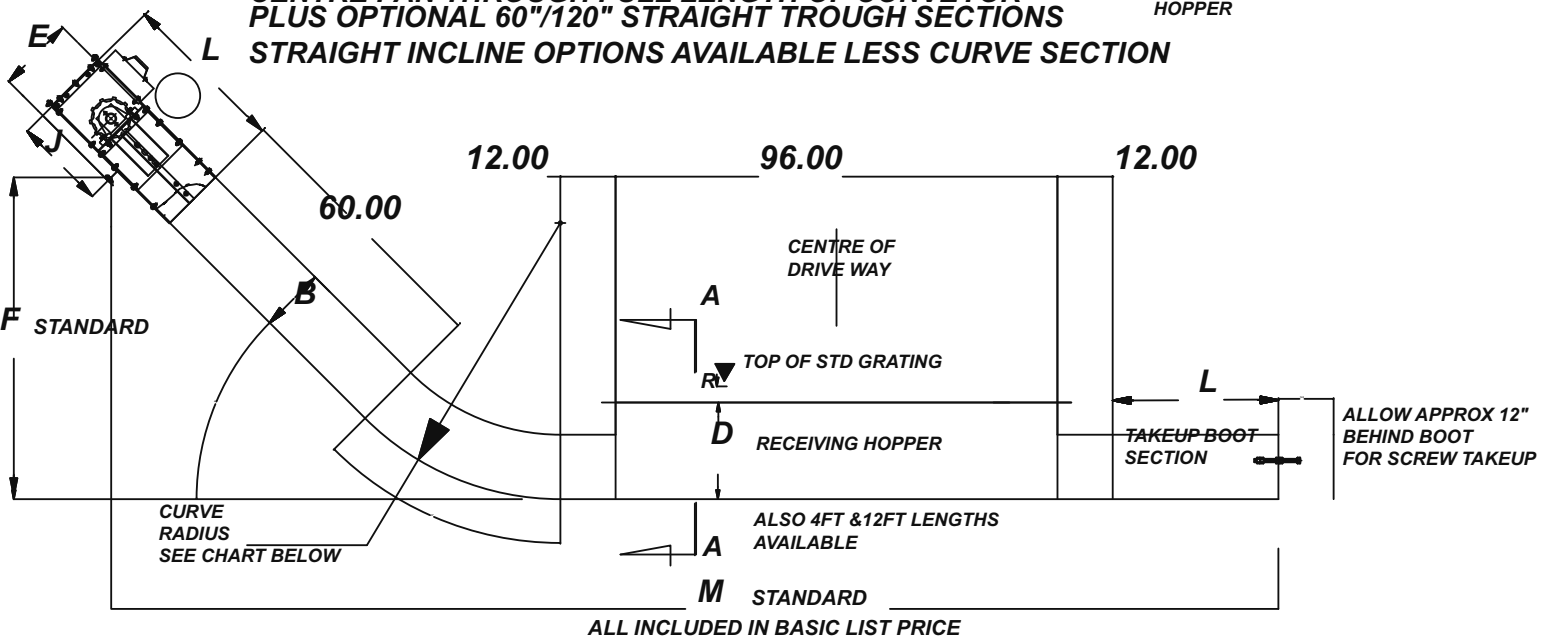

ALL INCLUDED IN BASIC LIST PRICE