

## FLAT BOTTOM LOW PROFILE CONVEYORS

---

### Head Features:

- Computer aided modular bolt together design
- CNC manufactured
- 10-8-5 gauge standard galvanized construction
- Heavy duty pillow block bearings
- Heavy duty drive sprocket
- Removable inspection cover
- Dust seals

### Trough features:

- Computer aided modular bolt together design
- CNC manufactured
- 10 gauge galvanized sides
- 10-8-5 gauge galvanized bottoms available
- UHMW return rollers
- Pre-assembled trunk sections
- Optional abrasion resistant steel liners for bottom and sides

### Tail Features:

- Computer aided modular bolt together design
- CNC Manufactured
- 10-8-5 gauge standard galvanized construction
- Heavy duty pillow block bearings
- Heavy duty sprocket
- Acme screw slack adjusters
- Removable inspection covers
- Dust seals

# FLAT BOTTOM LOW PROFILE CONVEYORS

---



BPH	DRAG SIZE	RPM	FPM
1,000	GLD-09x9	37	64
1,500	GLD-09x9	55	95
2,000	GLD-09x9	74	128
2,500	GLD-09x9	92	160
3,000	GLD-09x9	109	189
3,000	GLD-13x11	49	106
4,000	GLD-13x11	65	141
5,000	GLD-13x11	81	176
5,500	GLD-16x11	70	154
6,000	GLD-16x11	76	176
6,500	GLD-16x11	81	181
7,000	GLD-16x11	88	195

	9X9	13X11	16X11
A	9	13	13
B	9	11	11
C	31	31	31
D	25.5	25.5	25.5
E	9.25	11.25	11.25
F	24	24	24
G	9	6	9
H	9	10	12
J	13	16	16
L	19	20	20
M	3.5	3.5	3.5
N	36	36	36
P	20	20	20
Q	30	30	30
R	32	32	32

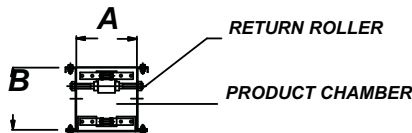
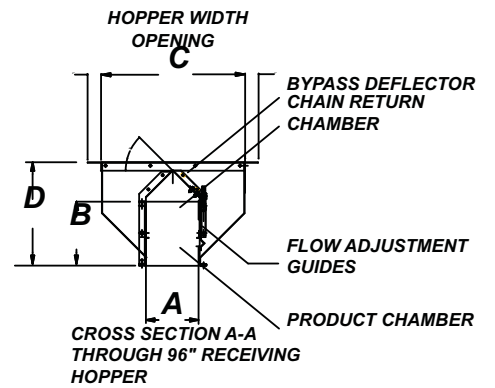
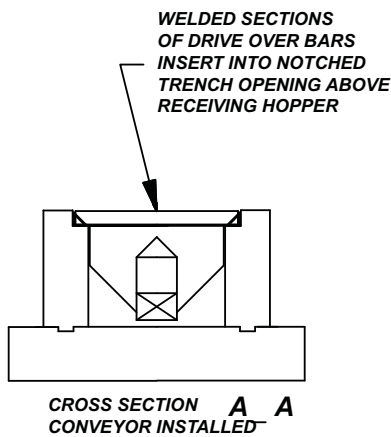
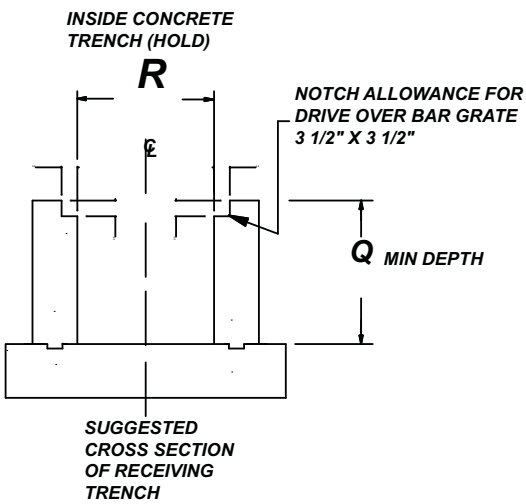

CROSS SECTION TYPICAL TROUGH

OPTIONAL RECEIVING HOPPER 96" ALSO 48" & 144" LENGTHS AVAILABLE

